



# TE-MDX-MT3

## DIMENSIONAL SCHEMATIC, PERFORMANCE AND PARTS LIST

### DIMENSIONS mm

not to scale  
specifications are subject to change

Inlet: 1/2" BSP.F  
Outlet: 1/2" BSP.M

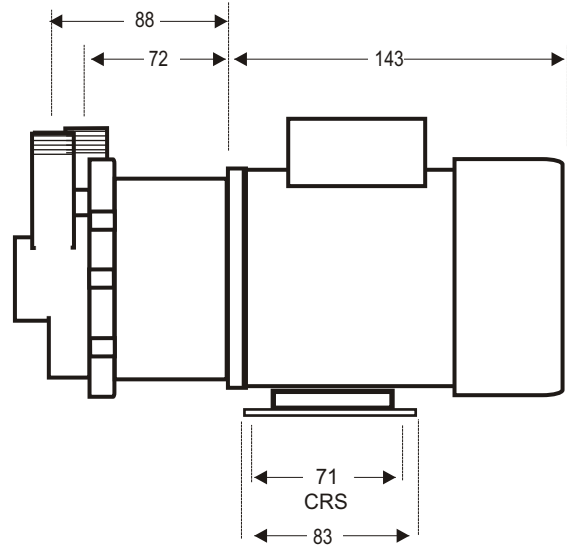
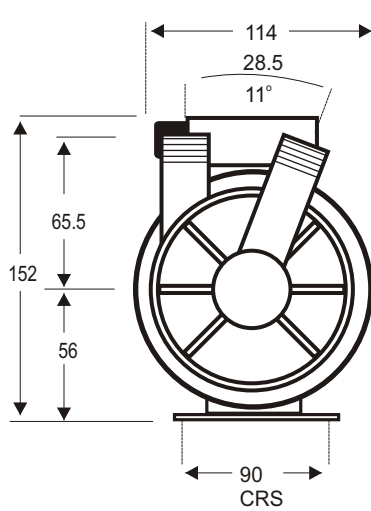

Details may change depending upon the motor specified

### PARTS LIST

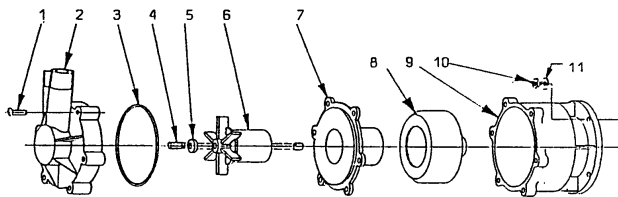

ITEM	DESCRIPTION	NOS	CODE
1	HOUSING SCREW ST/STEEL	6	0802-010-10
2	PUMP HOUSING POLYPROPYLENE	1	0135-128-10
3	'O' RING VITON	1	0135-046-UK
4	CERAMIC SPINDLE	1	0130-024-UK
5	THRUST WASHER CERAMIC	1	0130-028-UK
6	IMPELLER ASSY POLYPROPYLENE	1	0135-129-02
7	IMPELLER HOUSING POLYPRO	1	0135-127-10
8	DRIVE MAGNET ASSY (9mm )	1	0750-254-00
9	MOTOR BRACKET	1	0135-135-10
10	BRACKET FIXING SCREWS	4	0135-100-UK
11	BRACKET FIXING WASHERS	4	0135-200-UK
12	WET END ASSY ITEMS 1-7		0035-111-01
13	PUMP HEAD ASSY ITEMS 1-11		P035-111-012

### PERFORMANCE

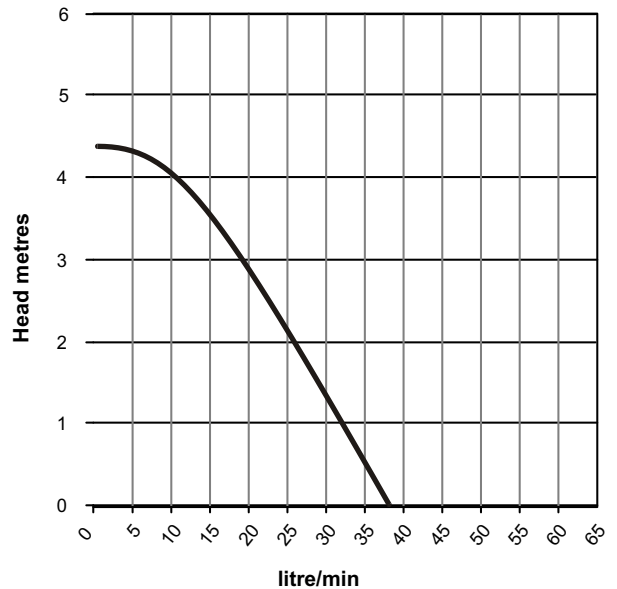

Tests obtained with water 1.0 SG

— 50 hz 2900 rpm