



PW-9E-MD 1.5sg

DIMENSIONAL SCHEMATIC AND PERFORMANCE

DIMENSIONS mm

not to scale
specifications are subject to change

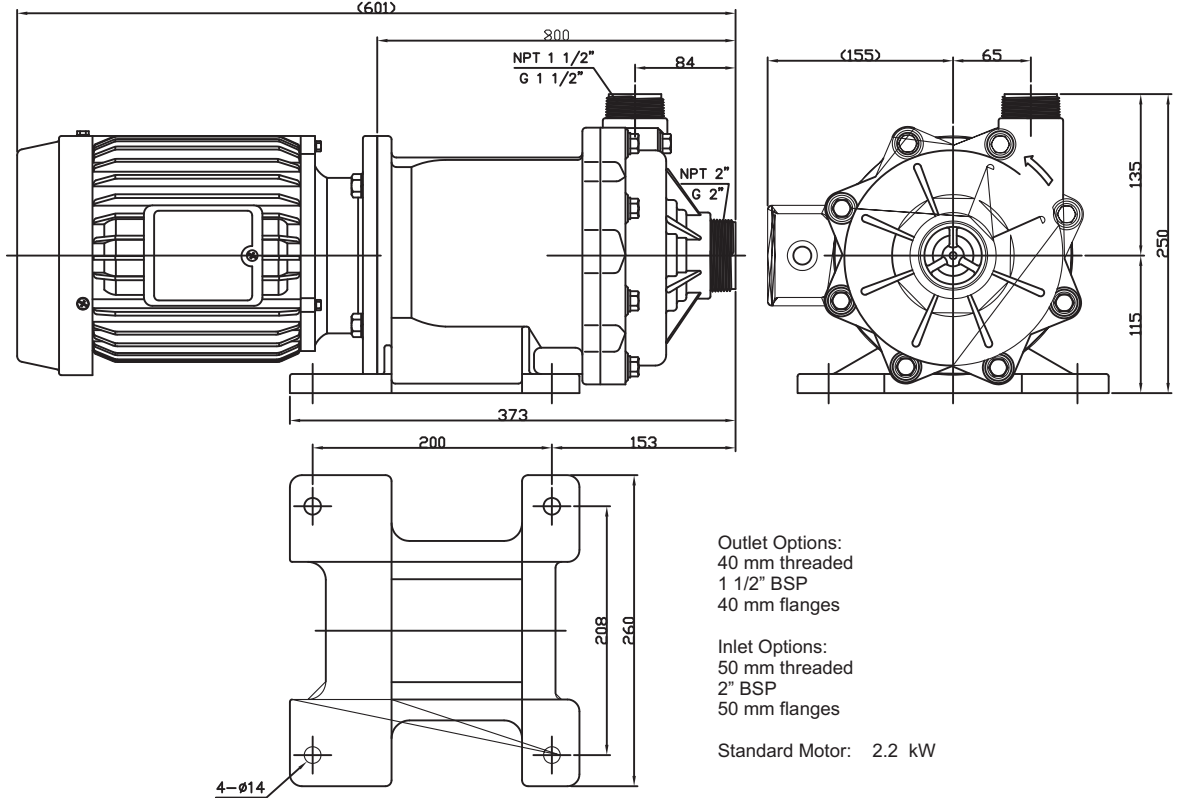

PERFORMANCE

Tests obtained
50 hz 2860 rpm
— 1.5 SG

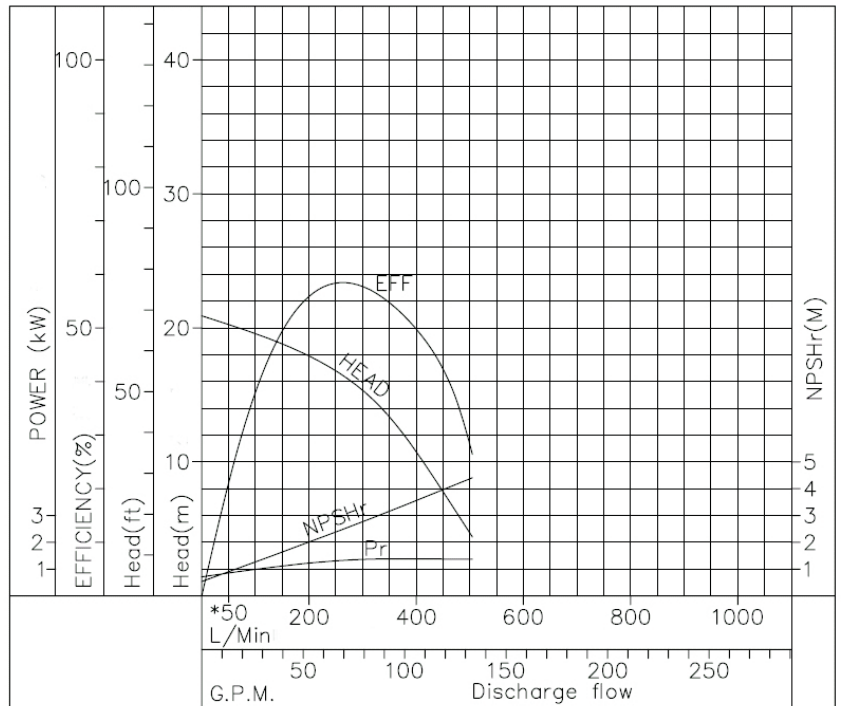

Performance may change depending upon the motor specified