



# MSP-5

## DIMENSIONAL SCHEMATIC, PERFORMANCE AND PARTS LIST

### DIMENSIONS mm

not to scale  
specifications are subject to change

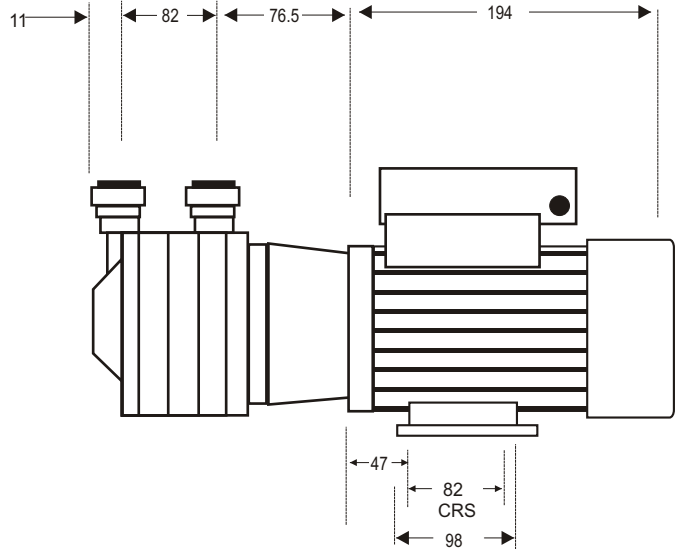
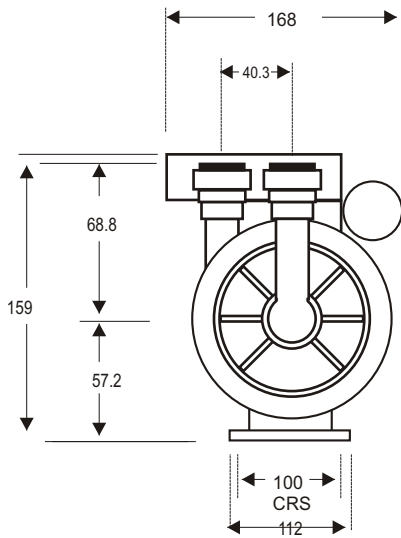

Details may change depending upon the motor specified

Standard motor: 300 watt

### PARTS LIST

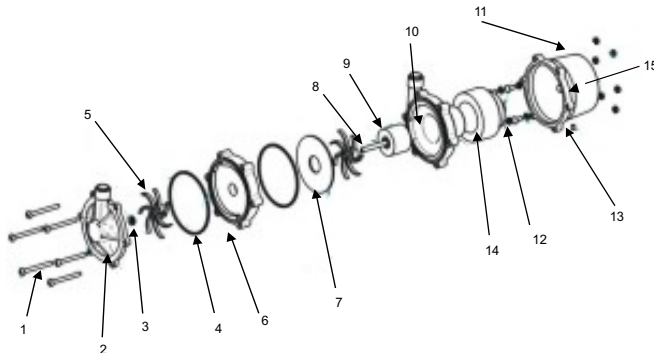

ITEM	DESCRIPTION	NOS	CODE
1	M5 x 90 Pozi Pan Screw St Stl Set	6	5020-213-50
2	MSP Front Cover PP JG	1	5020-110-01
	MSP Front Cover PP 1/2" NPTM	1	5020-111-01
	MSP Front Cover PP 3/4" BSPM	1	5020-112-01
3	Washer Thrust Ceramic	1	0130-028-UK
4	O Ring Id 87, 3mm C/Sec Nitrile	5	5020-122-30
5	Impeller PPS	5	5021-130-08N
6	Stage Housing	4	5020-150-01
7	Backing Plate	4	5020-160-13
9	Impeller magnet PPS	1	5021-191-08
8	Spindle St Stl 114mm	1	5021-233-51
10	MSP Pump Housing PP JG	1	5020-140-01
	MSP Pump Housing PP 1/2"NPTM	1	5020-141-01
	MSP Pump Housing PP 3/4"BSPM	1	5020-142-01
11	Full Nut M5 St Stl Set	6	5021-180-50
14	Drive Magnet	1	5021-204-56
12	Screw M5 x 12 Pozi Pan St Stl Set	5	5021-2212-50
13	Washer M5 Shakeproof St Stl Set	5	0135-200-UK
15	MSP Bracket PP	1	5020-170-01

### PERFORMANCE

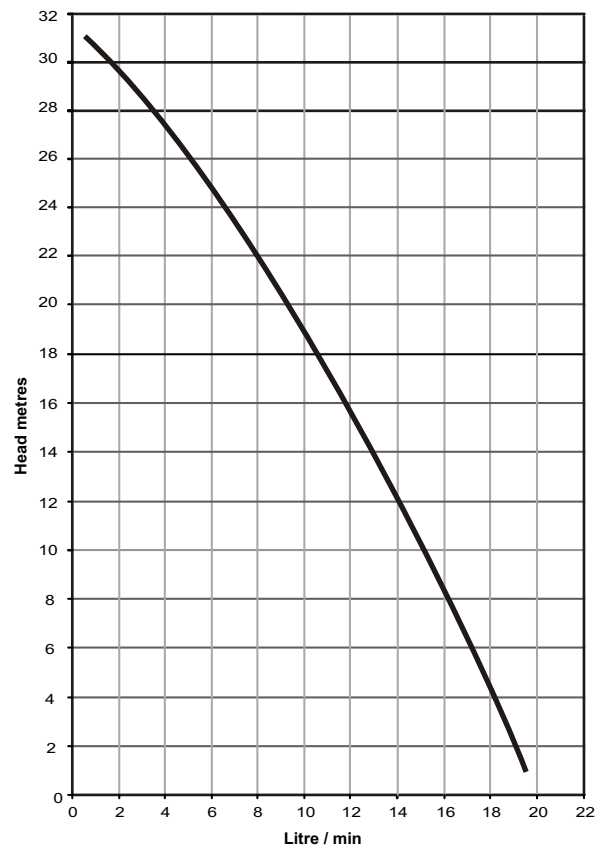

Tests obtained with water 1.0 SG

— 50 hz 2900 rpm