



AC-2CP-MD

DIMENSIONAL SCHEMATIC, PERFORMANCE AND PARTS LIST

DIMENSIONS mm

not to scale
specifications are subject to change

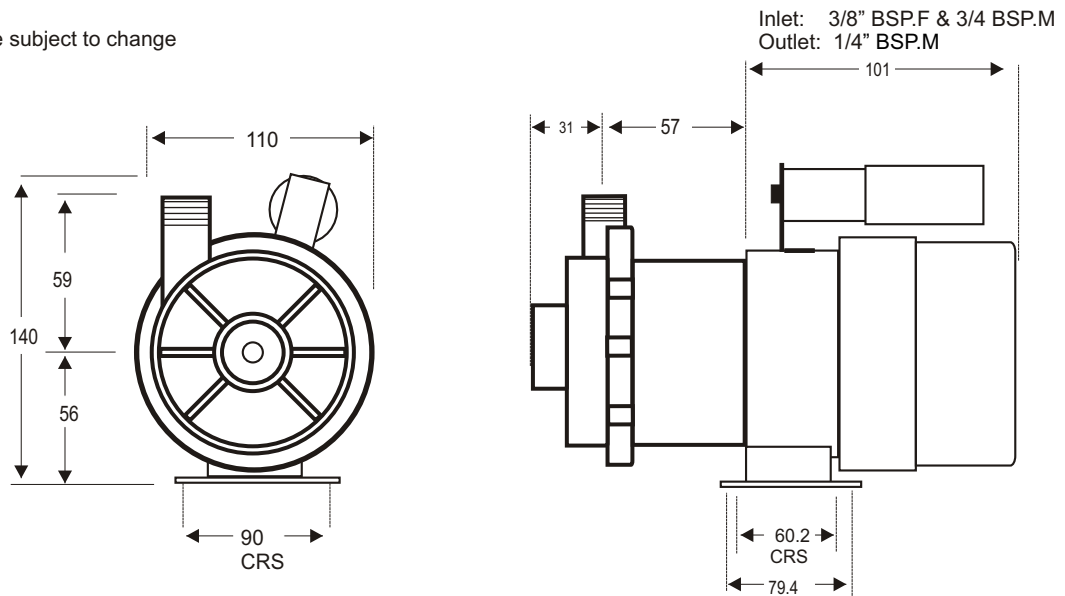

Details may change depending upon the motor specified

PARTS LIST

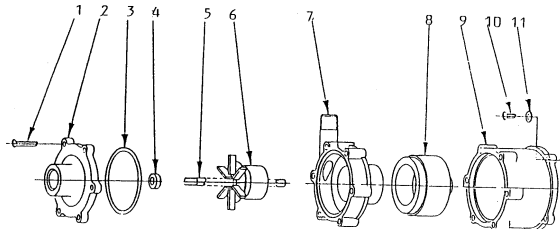

ITEM	DESCRIPTION	NOS	CODE
1	COVER SCREW	6	0115-062-10
2	COVER	1	0125-056-10
3	COVER 'O' RING	1	0125-065-UK
4	CERAMIC THRUST WASHER	1	0130-028-UK
5	IMPELLER SPINDLE CERAMIC	1	0125-061-10
6	IMPELLER & MAGNET ASSY	1	0125-055-01
7	PUMP HOUSING	1	0125-058-10
8	DRIVE MAGNET ASSY 5/16"	1	5002-200-01
9	MOTOR CONNECTING BRACKET	1	0125-069-10
10	SCREWS	4	5021-220-50
11	WASHERS	4	0858-004-UK
12	WET END ASSY ITEMS 1-7		0002-111-01
13	PUMP HEAD ASSY ITEMS 1-11		P002-111-011

PERFORMANCE

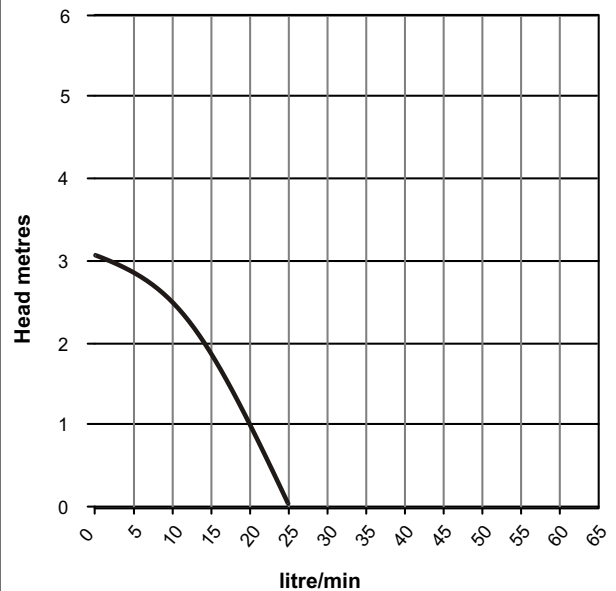

Tests obtained with water 1.0 SG

— 50 hz 2900 rpm